

NO	QTY	PART NO	DESCRIPTION	STD SEAL KIT	SPRING KIT
1	1	21430033	WASHER	X	X
2	1	23050005	RETAINING RING, BASIC INTERNAL	X	X
3	1	23350042	SPRING, COMPRESSION		X
4	1	39050001	BU RING, (-004)	X	
5	1	82110200	PISTON, CYL, CM, 125, .125 STRK		
6	1	82130202	RETAINER, CYL, CM, 125, .125 STRK	X	
7	1	82130203	GASKET, CYL, CM, 125 LB.	X	X
8	1	39H51003	O-RING, (-004)	X	
9	1	39H51004	O-RING, (-005)	X	
N/A	N/A	60210113	KIT, SEAL,	NOTED	N/A
N/A	N/A	61210310	KIT, SPRING	N/A	NOTED

NOTE:
 1. APPLY P.T.F.E. BASED OIL TO ALL SEALS PRIOR TO INSTALLATION.
 2. See IS-2100 for machining and installation instructions.
 3. DO NOT USE SILICONE BASED LUBRICANTS

INSTALLATION TORQUE:
 -Metal Gasket = 10 ft-lb
 *Cylinders may need to be re-torqued after a break-in period of 3 weeks or 2,500 cycles.

Use only one gasket. The metal gasket is recommended when the cavity seal surface has every smooth finish and is flat and perpendicular to the minor diameter. The metal gasket must be torqued to a higher value, which is more resilient to machining vibrations providing long term sealing.

PARTS LIST	 VEKTEK, INC. 1334 E. SIXTH AVE. P.O. BOX 625 EMPORIA, KS. 66801 U.S.A.	
	ASSEMBLIES AFFECTED 21-0102-00	PARTS LIST, ASSY, CYL, CM, 125, .125 STRK, SA
SIZE A	PL2175	REV D

D	3140	RELEASE	BCD	11/9/16
REV	IN ACCORDANCE WITH ECN	EFFECTIVE DATE	REVISED BY	DATE
DRW BY:	JDW	DRAWING STATUS: Released PRODUCTION APPROVED FOR RELEASED STATUS ONLY		
DATE:	6-7-04			

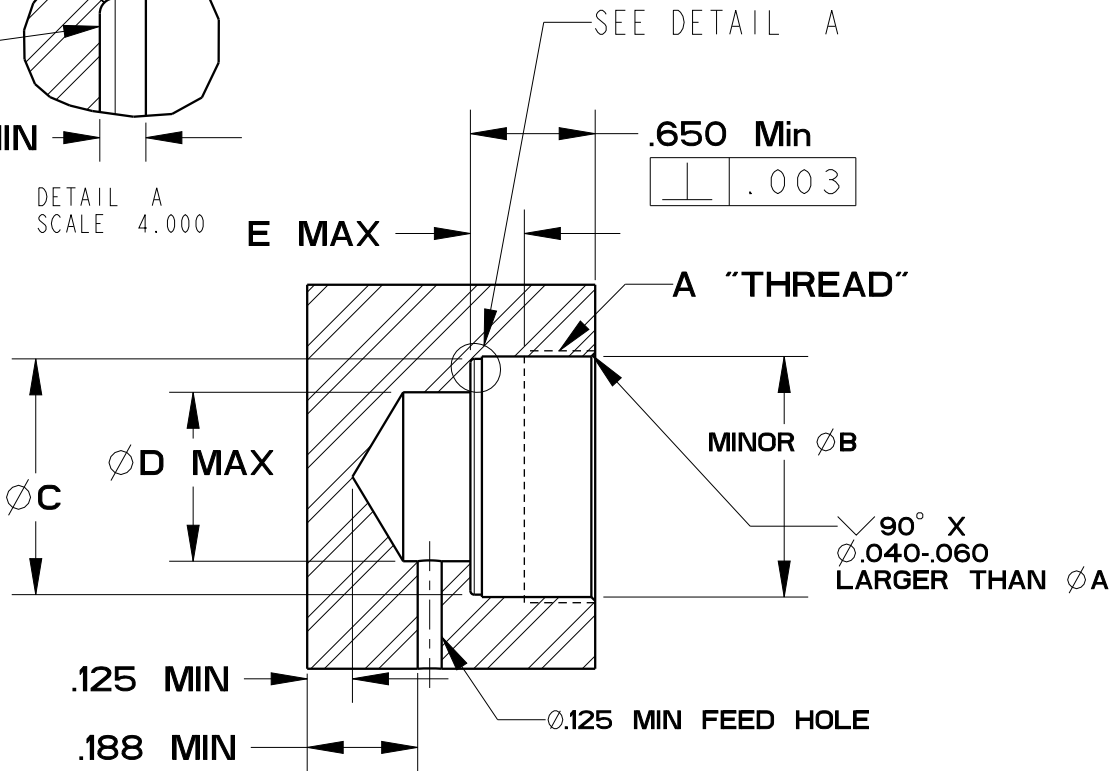
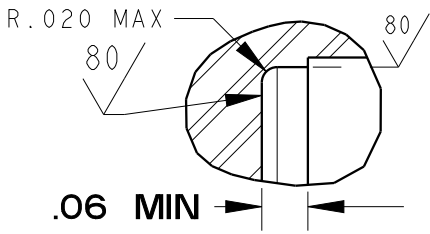

Tighten cylinders with a six point socket only !

Model No.	A	Metal Gasket Torque	Composite Gasket Torque	ØB	ØC	D	E
21-0102-00	3/8-24 UNF-2B	10 ft lb	NA	.335±.003	.325±.005	.13	.100
21-0104-02	5/8-18 UNF-2B	30 ft lb	15 ft lb	.572±.003	.545±.005	.31	.156
21-0105-03	3/4-16 UNF-2B	40 ft lb	20 ft lb	.690±.003	.662±.005	.38	.156
21-0105-04	3/4-16 UNF-2B	40 ft lb	20 ft lb	.690±.003	.662±.005	.38	.156
21-0105-05	3/4-16 UNF-2B	40 ft lb	20 ft lb	.690±.003	.662±.005	.38	.156
21-0105-06	3/4-16 UNF-2B	40 ft lb	20 ft lb	.690±.003	.662±.005	.38	.156
21-0108-04	1 1/16-16 UN-2B	50 ft lb	25 ft lb	1.002±.003	.923±.005	.63	.281
21-0108-05	1 1/16-16 UN-2B	50 ft lb	25 ft lb	1.002±.003	.923±.005	.63	.281
21-0108-08	1 1/16-16 UN-2B	50 ft lb	25 ft lb	1.002±.003	.923±.005	.63	.281
21-0110-04	1 5/16-16 UN-2B	NA	35 ft lb	1.253±.003	1.228±.005	.88	.281

*Cylinders may need to be re-torqued after a break-in period of 3 weeks or 2,500 cycles for both gasket styles.

Instruction Sheet



VEKTEK, INC.
1334 E. SIXTH AVE. P.O. BOX 625
EMPORIA, KS. 66801 U.S.A.

Model number
-See Chart-

Cavity Dimensions
Cartridge Mounted Cylinders

G	3041	RELEASE	BCD	11/9/16
REV	IN ACCORDANCE WITH ECN	EFFECTIVE DATE	REVISED BY	DATE
DRW BY:	DRAWING STATUS: Released			
DATE:	PRODUCTION APPROVED FOR RELEASED STATUS ONLY			

SIZE A	IS-2100	REV G
-----------	----------------	----------

FORM FEG041-IS-ASIZE, REV. B

SHEET 1 OF 1